

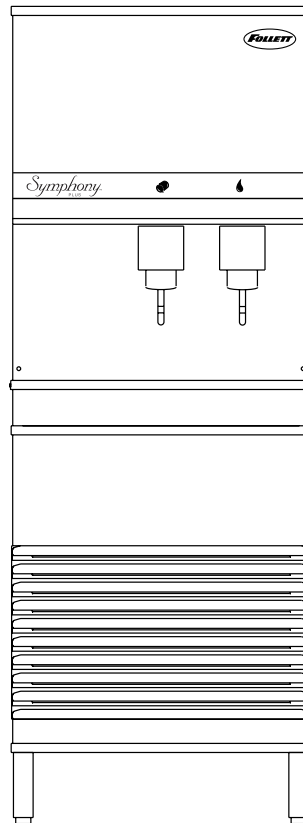

Symphony Plus™ 110 Series Ice and Water Dispensers 110FB414A/W

Operation and Service Manual

Please visit <https://www.follettice.com/technicaldocuments>
for the Operation and Service manual for your unit.



Welcome to Follett

Follett equipment enjoys a well-deserved reputation for excellent performance, long-term reliability and outstanding after-the-sale support. To ensure that this equipment delivers that same degree of service, review this guide carefully before you begin your installation.

Should you have need technical help, please call our Technical Service group at (877) 612-5086 or (610) 252-7301.

Please have your model number, serial number and complete and detailed explanation of the problem when contacting Technical Service.

Getting Started

After uncrating and removing all packing material. Inspect the equipment for concealed shipping damage. All freight is to be inspected upon delivery. If visible signs of damage exist, please refuse delivery or sign your delivery receipt "damaged." Follett Customer Service must be notified within 48 hours. Wherever possible, please include detailed photos of the damage with the original packaging so that we may start the freight claim process.

Contents

Welcome to Follett	1
Getting Started	1
Specifications	5
Electrical	5
Ambient	5
Plumbing	5
Ventilation clearances	5
Approximate shipping weight	5
Installation	6
Before you begin	6
Installing freestanding dispensers	6
User information	7
How the dispenser works	7
How SensorSAFE infrared dispensing works	7
Quiet Night™/Sleep cycle	7
Cleaning and sanitizing	8
Weekly	8
Monthly	8
Semi-Annually (more often if conditions dictate)	9
Ice Machine and Dispenser	9
Service	12
Lever models	12
SensorSAFE models	12
Dispenser troubleshooting	14
Lever model troubleshooting guide	14
SensorSAFE model troubleshooting guide	15
Disassembly and replacement instructions	16
Ice transport tube replacement – Freestanding units	17
Thermostat replacement	18
Replacement parts	19
Dispenser exterior	19
Wheelmotor and drive system	20
Dispense chute and splash panel (models with lever dispensing)	21
Dispense chute and splash panel (models with SensorSAFE infrared dispensing)	22
Electrical components	23
Hopper components	24
Ice transport tubing	25
Chilled water components	25
Dispenser plumbing connections	26
Solenoid dispense assembly	27
Water treatment accessories for Symphony Plus ice and water dispensers	28



WARNING! Risk of fire or explosion. Flammable refrigerant used. Follow handling instruction carefully. To be repaired only by trained service Personnel.



WARNING! Do not puncture Refrigerant Tubing. Do not use this product with flammable gases or flammable solvents.



WARNING! Do not store flammable gases, flammable liquids or flammable solids in these units. Do not use FLAME to check for gas leak.



WARNING! Do not under any circumstances try to modify or repair valves, regulator, connectors, controls or any other appliance. Doing so creates the risk of a gas leak.



WARNING! Keep ventilaton openings clear of obstruction.



WARNING! Do not damage the refrigerant circuit.



WARNING! Connect to potable water supply only.



WARNING!

Installation

- Read this manual thoroughly before operating, installing or performing maintenance on the equipment. Failure to follow instructions in this manual can cause property damage, personal injury, or death.
- The ice machine contains R290 (propane) refrigerant. R290 (propane) is flammable in concentrations of air between approximately 2.1% and 9.5% by volume. R290 (propane) may burn if exposed to a heat source above 470 °C.
- Because R290 is highly flammable, a combustible gas leak detector is required when servicing R290 systems.
- This equipment contains high-voltage electricity and refrigerant charge. Installation and Service repairs are to be performed by properly trained technicians aware of the dangers of dealing with high voltage electricity and refrigerant under pressure. The technician must also be certified in proper refrigerant handling and servicing procedures.
- All lockout and tag out procedures must be followed when working on this equipment.
- A qualified person shall provide a readily accessible disconnect device incorporated into the fixed wiring.
- This appliance should be permanently connected by a qualified person in accordance with application codes.
- If the supply cord is damaged, it must be replaced by the manufacturer, its service agent or similarly qualified persons in order to avoid a hazard.
- Do not tilt unit further than 30° off vertical during uncrating or installation.
- This appliance is designed for commercial use.
- This equipment is intended for indoor use only. Do not install or operate this equipment in outdoor areas.
- Warranty does not cover exterior or outside installations.
- To avoid a hazard due to instability of the appliance, it must be fixed in accordance with the instructions.
- Maintain all minimum clearances. DO NOT obstruct vents or openings.
- This appliance is not suitable for installation in an area where a water jet could be used.
- Connect to potable water supply only.
- Follett recommends a Follett water filter system be installed in the ice machine inlet water line (standard capacity, high capacity, carbonless high capacity).
- We reserve the right to make product improvements at any time. Specifications and design are subject to change without notice.

Usage

- Read this manual thoroughly before operating, installing or performing maintenance on the equipment. Failure to follow instructions in this manual can cause property damage, personal injury, or death.
- User maintenance should not be done by children.
- This appliance can be operated by children aged 8 years and above and persons with reduced physical, sensory, or mental capabilities, or lack of experience and knowledge if they have been given supervision or instruction concerning use of the appliance in a safe way and understand the hazards involved. Children should be supervised to ensure that they do not play with the appliance.
- If the supply cord is damaged, it must be replaced by the manufacturer, its service agent or similarly qualified persons in order to avoid a hazard.

- Routine adjustments and maintenance procedures outlined in this manual are not covered by the warranty.
- Maintain all minimum clearances. DO NOT obstruct vents or openings.
- This appliance must not be cleaned by a water jet.
- Connect to potable water supply only.
- Ice is food. Follow recommended cleaning instructions to maintain cleanliness of delivered ice.
- Ice is slippery. Maintain counters and floors around dispenser in a clean and ice-free condition.
- We reserve the right to make product improvements at any time. Specifications and design are subject to change without notice.

Service

- Read this manual thoroughly before operating, installing or performing maintenance on the equipment. Failure to follow instructions in this manual can cause property damage, personal injury, or death.
- Review Installation section.
- This equipment contains high-voltage electricity and refrigerant charge. Installation and Service repairs are to be performed by properly trained technicians aware of the dangers of dealing with high voltage electricity and refrigerant under pressure. The technician must also be certified in proper refrigerant handling and servicing procedures.
- To reduce risk of shock, disconnect power before servicing.
- When servicing this equipment, be sure to lock the circuit breaker, and display an in-service notice.
- Repair on R290 systems must always be done in a well-ventilated area.
- If the supply cord is damaged, it must be replaced by the manufacturer, its service agent or similarly qualified persons in order to avoid a hazard.
- Only use parts recommended or provided by the manufacturer. Use of unapproved parts can be dangerous due to design requirements to safely use R290 (propane).
- Routine adjustments and maintenance procedures outlined in this manual are not covered by the warranty.
- Maintain all minimum clearances. DO NOT obstruct vents or openings.
- This appliance must not be cleaned by a water jet.
- Connect to potable water supply only.
- We reserve the right to make product improvements at any time. Specifications and design are subject to change without notice.

Decommissioning and Dismantling

- Read this manual thoroughly before operating, installing or performing maintenance on the equipment. Failure to follow instructions in this manual can cause property damage, personal injury, or death.
- Decommissioning and Dismantling are to be performed by properly trained technicians aware of the dangers of dealing with high voltage electricity and refrigerant under pressure. The technician must also be certified in proper refrigerant handling procedures for R290 (flammable) refrigerant.
- Review Installation section.
- Ensure area is being well-ventilated before Decommissioning and Dismantling of equipment using R290 (flammable) refrigerant.
- When servicing this equipment, be sure to lock the circuit breaker, and display an in-service notice.
- To reduce risk of shock, disconnect power before servicing.
- Utilize and maintain good safety practices and follow all applicable local, state, and federal regulations for proper decommissioning and disposal of the equipment.
- Ensure all personal protective equipment is used during the entire process.
- Ensure all necessary tools and equipment are available, including recovery equipment and cylinders.
- All containers used for recovery must have proper labelling to ensure they can be used for R290 (flammable) refrigerant.
- Before starting recovery, place refrigerants on scales. Do not overfill containers more than 80% of volume, and do not exceed working pressure of the container.
- Before using a recovery machine, ensure that it is in satisfactory working order and that the electrical components are properly sealed to prevent any type of ignition.
- Recovered refrigerant shall not be added or used in another refrigerating system or mixed into another container.
- If the compressor or compressor oils are removed, ensure it has been removed to an acceptable level so that flammable refrigerant does not remain in the lubricant.

Disposal

- Follow all applicable local, state, and federal regulations for proper disposal of the equipment.
- All recovered refrigerant must be returned to an appropriate refrigerant supplier for proper disposal.
- DO NOT dispose of your appliance with household waste.

Specifications

Electrical

- Freestanding models require a dedicated circuit.

	Total system	Max. circuit
Basic electrical: 115 V/60 Hz/1 phase	11.0A	20A

- Dispensers and ice machines are supplied with 7-foot power cord with NEMA 5-15 hospital-grade plug. Connect to a dedicated 15A circuit.

Model	Electrical connection	Circuits required
110FB414A/W	cord & plug provided	115/60/1, 15A max. fuse size

Ambient

Air temp*	100 F/38 C Max.	50 F/10 C Min. (Best performance below 80 F/27 C)
Water temp†	90 F/32 C Max.	45 F/7.2 C Min. (Best performance below 70 F/21 C)
Water pressure (psi/bar)	70/5 Max.	10/0.7 Min.

* Ambient air temperature is measured at the air-cooled condenser coil inlet.

† Ambient water temperature is measured in the ice machine reservoir.

Plumbing

	110FB with ice machine in base
Dispenser drain	3/4" MPT
Ice machine drain	3/4" MPT
Dispenser water inlet	3/8" FPT
Ice machine water inlet	—
Cond. inlet – w/c only	3/8" FPT
Cond. drain – w/c only	3/8" FPT

Note: Water shut-off recommended within 10 ft (3 m) of dispenser. Drain to be hard-piped and insulated. Maintain at least 1/4" per foot (20 mm per 1 m) run of slope.

Ventilation clearances

- **110FB414A/W:** 4" (10.2 cm) required at rear .

Note: 12" (30.5 cm) at top advised for service.

Approximate shipping weight

- 290 lb (132 kg), base stand: 140 lb (64 kg)

Installation

Before you begin

- All dispensers must be installed level in both directions to ensure proper operation.
- All countertop dispensers provide the option of taking utilities out the bottom or back of the dispenser. See counter cut-out (**Fig. 2**) for bottom exiting utilities on units with and without drain pans. For installations where utilities will exit through back of dispenser, refer to back view drawings.

Installing freestanding dispensers

1. Position dispenser in desired location and adjust legs to level in both directions.
2. Connect water supply to 3/8" FPT fitting on back of dispenser (**Fig. 1**).
3. Connect separate drain lines to 3/4" MPT dispenser drain fitting, and 3/4" MPT ice machine drain fitting on back of dispenser.
4. Run drain lines to wall or floor drain. If ice machine drain fitting is below an intended wall drain, a condensate pump must be used.
5. If ice machine is a water-cooled unit, connect water-cooled condenser supply line to 3/8" FPT condenser inlet fitting on back of dispenser.
Note: Do not run condenser supply water through ice machine water filter system.
6. Connect condenser drain line to 3/8" FPT condenser outlet fitting on back of dispenser.
Important: Do not connect condenser drain line to any other drain lines.
7. Plug dispenser into 15A rated NEMA 5-15 circuit.
8. Remove front cover of base section by removing two screws at bottom corners of cover. Allow cover to drop approximately 3/8" (5 mm) and pull forward.
9. Turn on water supply and check for leaks.

Fig. 1 – Rear connections, freestanding models

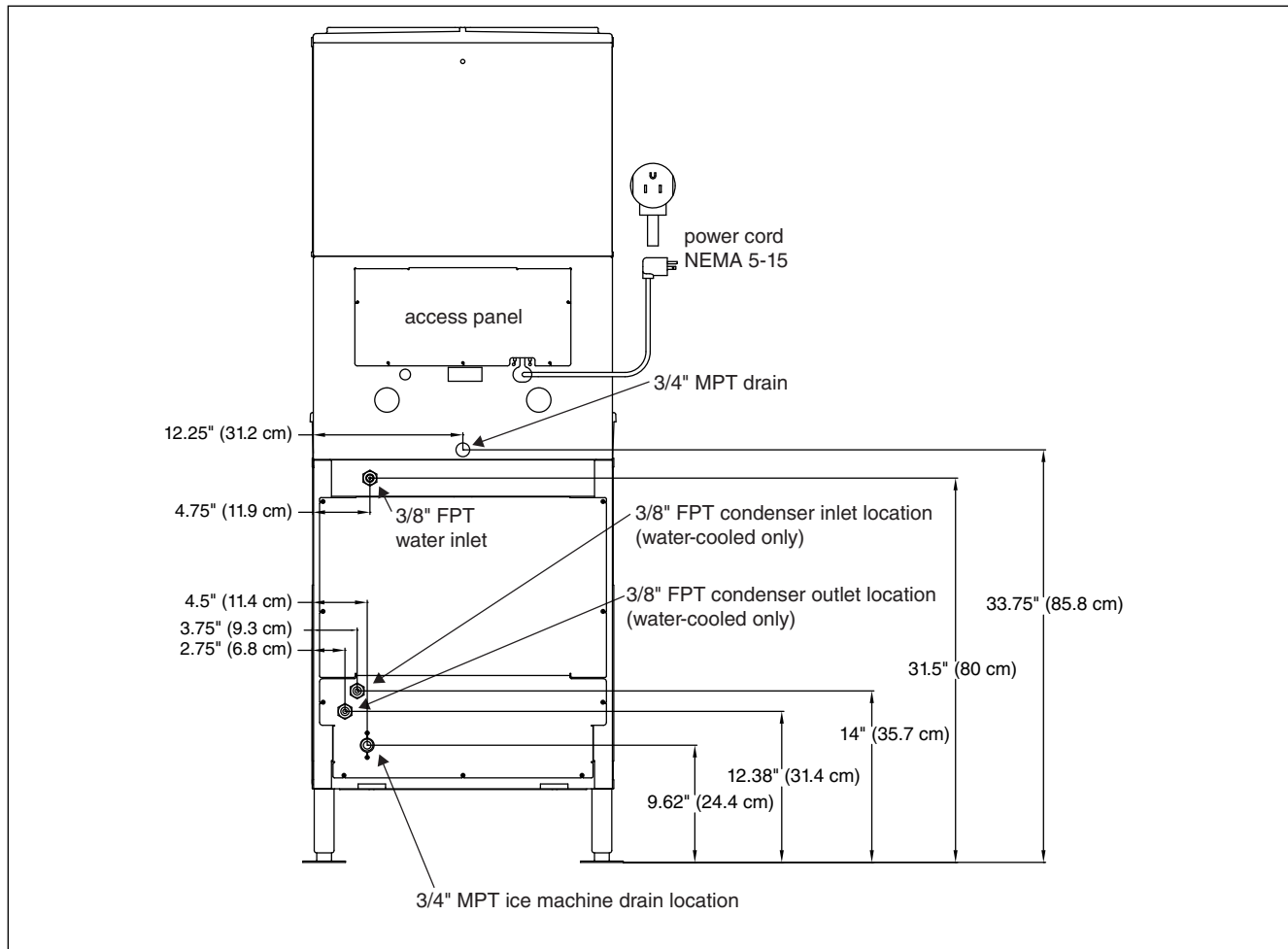

10. Remove top front cover by removing two screws at bottom corners of cover. Lift cover slightly and pull forward.
11. If dispenser is equipped with SensorSAFE™, remove protective plastic coating from dispense sensor labels.
12. Turn on dispenser power and bin signal rocker switches. Check dispenser and ice machine operation.
13. Clean ice machine according to instructions in the Cleaning section. Discard ice made during cleaning process.
14. Turn off ice machine bin signal switch.
15. Remove dispenser hopper lid; clean dispenser according to instructions.
16. Turn ice machine bin signal switch on and replace front covers, securing with screws.

User information

How the dispenser works

Follett's 110 series automatic-load ice and water dispensers are equipped with Follett's 425 lb (193 kg)/day ice machine. In the continuous icemaking process, water freezes to the inside wall of the evaporator. A rotating stainless steel auger carries the ice to the top of the evaporator where it is compressed and extruded through an outlet port. The ice is then pushed through a tube to the storage hopper. When the hopper is full, a bin thermostat opens and shuts the ice machine off. When the dispense mechanism is activated, a dispense motor is turned on, causing the wheel to turn. This moves ice to the dispense chute where it drops by gravity into the container held below the chute.

How SensorSAFE infrared dispensing works

Follett's SensorSAFE infrared dispensing maximizes sanitation and minimizes the possibility of cross-contamination by eliminating physical contact between the cup or container and dispenser. Sensors in the panel use reflected infrared light to detect the presence of the container and send a signal to a control board which then activates the appropriate components for ice or water dispensing.

The SensorSAFE infrared dispensing package includes a cleaning switch under the left side of the front cover which temporarily shuts off dispensing to allow cleaning of the panel and lenses. If the switch is not turned back on after cleaning, the dispenser automatically resets after two minutes for normal operation.

SensorSAFE infrared dispensing also includes a time limit safety feature which automatically stops ice dispensing after one minute of continuous dispensing. Dispensing can be resumed by moving the container away from the dispenser and returning it to the activation zone.

Quiet Night™/Sleep cycle

The board monitors ice dispensing through a line voltage input to P15. If the ice dispense has not been initiated for more than 5 seconds during the 20 minute time delay, the **SLEEP CYCLE** LED comes on. The machine will stay off for 12 hours unless 5 seconds of dispensing is seen. After 12 hours, the **SLEEP CYCLE** LED goes out and the ice making will resume if the bin thermostat is closed. The sleep cycle can be deated using the DIP switches on the ice machine control board.

Cleaning and sanitizing

Follett ice machines and dispensers, and their associated cleaning and sanitizing procedures, are designed for use with potable water sources. The presence, or suspected presence, of infectious agents may call for additional measures, including the replacement of components and more comprehensive disinfection measures. Follett recommends that these cleaning and sanitizing procedures be reviewed with the appropriate infectious agent subject matter experts to assure complete remediation.

Periodic cleaning of Follett's ice and water dispenser and ice machine system is required to ensure peak performance and delivery of clean, sanitary ice. The recommended cleaning procedures that follow should be performed at least as frequently as recommended and more often if environmental conditions dictate.

Follett recommends sanitizing the pressurized water lines prior to cleaning the ice machine/dispenser. Follett offers two kits: order P/N 01089572 when a Follett filter system with a pre-filter bowl is present, or P/N 01089580 when a Follett filter system is not present. Follow the instructions provided with the respective kits to sanitize the pressurized water lines immediately before cleaning the ice machine/dispenser.

Cleaning of the condenser can usually be performed by facility personnel. Cleaning of the ice machine system should be performed by your facility's trained maintenance staff or a Follett authorized service agent. Regardless of who performs the cleaning, it is the operator's responsibility to see that this cleaning is performed according to the schedule below. Service problems resulting from lack of preventive maintenance will not be covered under the Follett warranty.

Recommended cleaning intervals*

Symphony Plus	Frequency
Drain Line	weekly
Drain Pan/Drip Pan	weekly
Exterior, Water Station Tube	as needed
Condenser	monthly (air-cooled only)
Dispenser and Components	semi-annually
Ice Machine	semi-annually
Transport Tube	semi-annually
Ice Storage Area/Bin	semi-annually
Pressurized Water Sanitizing	semi-annually

* Ice machine and dispenser must be cleaned prior to start-up.

Weekly

CAUTION!

- Do not use solvents, abrasive cleaners, metal scrapers or sharp objects to clean any part of the dispenser.

Dispenser drain pan and drain line

- Pour 1 gal. (3.8 L) of hot tap water into drain pan to flush drains.

Splash panel front, SensorSAFE infrared dispensing

- Deactivate dispensing by pressing and releasing clean switch located on left side of unit under top front cover.
- Clean lens and splash panel front using a soft cloth and mild, non-abrasive, non-chlorine based cleaner.
- Reactivate dispensing by pressing and releasing clean switch again.

Monthly

CAUTION!

- Do not use solvents, abrasive cleaners, metal scrapers or sharp objects to clean any part of the dispenser.

Condenser (air-cooled ice machine only)

- Use a vacuum cleaner or stiff brush to carefully clean condenser coils of lint and debris to ensure optimal performance.

Semi-Annually (more often if conditions dictate)

- A cleaning procedure should always include both the ice machine and dispenser.
- Icemaking system can be cleaned in place.



CAUTION!

- Wear rubber gloves and safety goggles (or face shield) when handling SafeCLEAN Plus™ and IMS-III solutions.
- Use only Follett approved cleaners.
- It is a violation of Federal law to use the Nu-Calgon® IMS-III solution in a manner inconsistent with its labeling.
- Do not use solvents, abrasive cleaners, metal scrapers or sharp objects to clean any part of the dispenser.

Cleaning Tool Checklist

- (1 or 2) 1.5 gallon (or larger) plastic bucket
- (2) clean cloths
- Sanitary gloves
- Safety glasses
- (2) SaniSponge™ (P/N 00131524 - single sponge)
- SafeCLEAN Plus ice machine cleaner
- [OPTIONAL] Nu-Calgon IMS-III no-rinse sanitizer (P/N 00979674 – 16 fl oz. bottle)

SafeCLEAN Plus Solution: Follow the directions on the SafeCLEAN Plus packaging to mix 1 gal. (3.8 L) of Follett SafeCLEAN Plus solution. Use 100 F (38 C) water.

[OPTIONAL] No-rinse Sanitizing Solution: Follow the directions on the Nu-Calgon IMS-III packaging to mix 1 gal. (3.8 L) of IMS-III solution. Use 100 F (38 C) water.

Ice Machine and Dispenser

Cleaning Procedure

Note: Check drains and drain cup to ensure they are open and flowing freely.

1. If ice machine was running recently, ensure that the evaporator is completely free of ice before proceeding. If there is ice in the evaporator, complete steps 2-7 using only hot water to remove the ice, then begin Cleaning/Descaling Procedure again.
2. Remove front cover and turn OFF bin signal switch.
3. Dispense all ice from storage hopper and discard.
4. Remove hopper lid.
5. Remove water reservoir drain tube from the evaporator drain bracket and lift tube to higher level than reservoir, placing it in plastic clip at right lower front.
6. Remove lid from cleaning cup, then hang the cleaning cup on plastic clip at left front of dispenser. Set cleaning cup lid aside, but do not discard.
7. Press **CLEAN** switch. The **MAINTENANCE** light will turn on and the machine will fill and drain three times. Wait for the **LOW WATER** light to turn on.
8. Fill cleaning cup until SafeCLEAN Plus solution completely fills the reservoir (about 1 quart). Place lid back on cup. Save remainder of SafeCLEAN Plus solution.
9. **CLEANER FULL** light will turn on and machine will start cleaning cycle then rinse three times; this process takes approximately 15 minutes.

10. While ice machine is cleaning, clean dispenser as follows:
 - 10.1 Remove knurled nuts from front of storage hopper.
 - 10.2 Remove stud assembly, baffle, wheel, and any remaining ice.
 - 10.3 Remove dispense chutes from splash panel.
 - 10.4 Submerge drain grill in SafeCLEAN Plus solution and allow to soak to remove any scale buildup.
 - 10.5 Wipe inside of hopper lid, stud assembly, baffle, wheel, inside of storage area, dispense chutes, drain grill and drain pan with damp cloth wrung out in SafeCLEAN Plus solution. Thoroughly rinse all parts with damp cloth wrung out with clean water.

Note: To avoid possible damage to motor assembly, only use a damp cloth to clean storage hopper. Do not allow water to run through motor shaft hole in bottom of hopper.

- 10.6 When machine is finished cleaning, the MAINTENANCE light will turn off.
11. Reinstall dispense chutes, wheel, baffle, stud assembly and knurled nuts. (See manual for correct baffle position.)

Finish cleaning – SafeCLEAN Plus only

12. Remove top bearing insulation. Loosen Phillips-head screw on nozzle connected to evaporator. Remove nozzle from evaporator side only, leave other side of nozzle connected to transport tube.
13. Soak both Sani-Sponges in remaining SafeCLEAN Plus solution.
14. Insert both sponges soaked in SafeCLEAN Plus solution into nozzle one at a time.
15. Replace nozzle onto evaporator and tighten screw. Ensure drain is connected to reservoir and vent tubes are connected to evaporator drain pan. Replace top bearing insulation.
16. Lower water reservoir drain tube back to evaporator drain bracket.
17. Turn ON bin signal switch. Wait for ice to push sponges through transport tube.
18. Collect sponges from ice storage bin.
19. Replace hopper lid, machine top, turn ON dispenser power and install front cover.
20. After 10 minutes, dispense all ice and discard. 12. Remove top bearing insulation. Loosen Phillips-head screw on nozzle connected to evaporator. Remove nozzle from evaporator side only, leave other side of nozzle connected to transport tube.
21. Soak both Sani-Sponges in remaining SafeCLEAN Plus solution.
22. Insert both sponges soaked in SafeCLEAN Plus solution into nozzle one at a time.
23. Replace nozzle onto evaporator and tighten screw. Ensure drain is connected to reservoir and vent tubes are connected to evaporator drain pan. Replace top bearing insulation.
24. Lower water reservoir drain tube back to evaporator drain bracket.
25. Turn ON bin signal switch. Wait for ice to push sponges through transport tube.
26. Collect sponges from ice storage bin.
27. Replace hopper lid, machine top, turn ON dispenser power and install front cover.
28. After 10 minutes, dispense all ice and discard.

[OPTIONAL] Finish cleaning – No-rinse sanitizing with Nu-Calgon IMS-III

10. Press **CLEAN** switch. The **MAINTENANCE** light will turn on and the machine will fill and drain three times. Wait for the **LOW WATER** light to turn on.
11. Remove lid from cleaning cup and fill (about 1 quart) until sanitizing solution completely fills the reservoir. Place lid back on cup. Save remainder of sanitizing solution.
12. **CLEANER FULL** light will turn on and machine will start sanitizing cycle, then rinse three times; this process takes approximately 15 minutes.
13. While ice machine is sanitizing, sanitize dispenser as follows:
 - 28.7 Wipe inside of hopper lid, stud assembly, baffle, wheel, inside of storage area, dispense chutes, drain grill and drain pan with damp cloth wrung out in sanitizing solution. Do not rinse off the sanitizing solution.

Note: To avoid possible damage to motor assembly, only use a damp cloth to clean storage hopper. Do not allow water to run through motor shaft hole in bottom of hopper.
14. Reinstall dispense chutes, wheel, baffle, stud assembly and knurled nuts. (See manual for correct baffle position.) Reinstall dispense chutes, wheel, baffle, stud assembly and knurled nuts. (See manual for correct baffle position.)
15. When machine is finished rinsing, the **MAINTENANCE** light will turn off.

16. Remove top bearing insulation. Loosen Phillips-head screw on nozzle connected to evaporator. Remove nozzle from evaporator side only, leave other side of nozzle connected to transport tube.
17. Soak one SaniSponge in remaining sanitizing solution. Insert the sponge soaked in sanitizing solution into nozzle, then insert a dry sponge into the nozzle.
18. Replace nozzle onto evaporator and tighten screw. Ensure drain is connected to reservoir and vent tubes are connected to evaporator drain pan. Replace top bearing insulation.
19. Turn ON bin signal switch. Wait for ice to push sponges through transport tube.
20. Collect sponges from ice storage bin.
21. Replace hopper lid, base stand cover, and install dispenser front cover.
22. After 10 minutes, dispense all ice and discard.

User Interface and Exterior Cabinet

- Clean stainless steel panels with stainless steel cleaner.

Service

Lever models

The dispense wheelmotor is energized through the power and ice dispense switches. The water solenoid valve is energized through the power and water dispense switches. The ice machine is controlled through an unpowered contact closure bin thermostat circuit. When ice builds up around the bin thermostat, the contacts open, cutting the bin signal to the ice machine.

SensorSAFE models

SensorSAFE models provide “touchless” ice and water dispensing. When a container is placed within the actuation zone below the ice or water chute on SensorSAFE dispenser models, an infrared signal reflects off the container and is detected by the sensor. The sensor then sends a signal to the control board to activate the appropriate components to dispense ice or water. LEDs on the board indicate when the board is receiving a signal from the sensors.

A safety, shut-off feature automatically shuts off dispensing after one minute of continuous activation. Dispensing can be restarted by moving the container away and then returning it to the actuation zone.

Dispensing can be temporarily suspended for cleaning by depressing and releasing the clean switch, located under the left side of the top front cover. Depressing and releasing the button a second time will return the dispenser to normal operating state. If the clean switch is not depressed a second time, the dispenser will automatically resume normal dispense operation (CLN LED goes out) after two minutes. An LED on the control board will light to indicate that the dispensing has been suspended by activation of the clean switch.

DIP Switch Settings

OFF POSITION ON POSITION

D414AT, D414AS

Sleep cycle disabled Not used Sleep cycle dispense duration 20 min. time delay Flush disabled Maint. timer ON	OFF ON → <input checked="" type="checkbox"/> <input type="checkbox"/> ↻ <input checked="" type="checkbox"/> <input type="checkbox"/> ∞ <input type="checkbox"/> <input type="checkbox"/> ↗ <input checked="" type="checkbox"/> <input type="checkbox"/> Ⓢ <input checked="" type="checkbox"/> <input type="checkbox"/> Ⓞ <input checked="" type="checkbox"/> <input type="checkbox"/> ↘ <input checked="" type="checkbox"/> <input type="checkbox"/> ∞ <input checked="" type="checkbox"/> <input type="checkbox"/> DIP	Sleep cycle enabled Not used Sleep cycle dispense duration 60 min. time delay Flush enabled Maint. timer OFF
--	---	---

414A installed in Symphony Plus 25/50/110 CI, CT, or FB

Sleep cycle disabled Not used Sleep cycle dispense duration 20 min. time delay Flush disabled Maint. timer ON	OFF ON → <input checked="" type="checkbox"/> <input type="checkbox"/> ↻ <input checked="" type="checkbox"/> <input type="checkbox"/> ∞ <input type="checkbox"/> <input type="checkbox"/> ↗ <input checked="" type="checkbox"/> <input type="checkbox"/> Ⓢ <input checked="" type="checkbox"/> <input type="checkbox"/> Ⓞ <input checked="" type="checkbox"/> <input type="checkbox"/> ↘ <input checked="" type="checkbox"/> <input type="checkbox"/> ∞ <input checked="" type="checkbox"/> <input type="checkbox"/> DIP	Sleep cycle enabled Not used Sleep cycle dispense duration 60 min. time delay Flush enabled Maint. timer OFF
--	---	---

Replacement P414A/W installed in Symphony dispenser

Sleep cycle disabled Not used Sleep cycle dispense duration 20 min. time delay Flush disabled Maint. timer ON	OFF ON → <input checked="" type="checkbox"/> <input type="checkbox"/> ↻ <input checked="" type="checkbox"/> <input type="checkbox"/> ∞ <input type="checkbox"/> <input type="checkbox"/> ↗ <input checked="" type="checkbox"/> <input type="checkbox"/> Ⓢ <input checked="" type="checkbox"/> <input type="checkbox"/> Ⓞ <input checked="" type="checkbox"/> <input type="checkbox"/> ↘ <input checked="" type="checkbox"/> <input type="checkbox"/> ∞ <input checked="" type="checkbox"/> <input type="checkbox"/> DIP	Sleep cycle enabled Not used Sleep cycle dispense duration 60 min. time delay Flush enabled* Maint. timer OFF
--	---	--

Sleep cycle dispense duration

OFF ON → <input type="checkbox"/> <input type="checkbox"/> ↻ <input type="checkbox"/> <input type="checkbox"/> ∞ <input type="checkbox"/> <input type="checkbox"/> ↗ <input type="checkbox"/> <input type="checkbox"/> Ⓢ <input type="checkbox"/> <input type="checkbox"/> Ⓞ <input type="checkbox"/> <input type="checkbox"/> ↘ <input type="checkbox"/> <input type="checkbox"/> ∞ <input type="checkbox"/> <input type="checkbox"/>	4 <input checked="" type="checkbox"/> <input type="checkbox"/> 35 s 5 <input checked="" type="checkbox"/> <input type="checkbox"/> 5 s 4 <input type="checkbox"/> <input checked="" type="checkbox"/> 15 s 5 <input type="checkbox"/> <input checked="" type="checkbox"/> 60 s
--	---

* Flush can be enabled on Symphony CT and FB models. Flush should be disabled on Symphony CI units due to risk of internal leak if drain line is blocked. All Symphony Plus models should be set to Flush enabled.

Electrical control system schematic

25/50/110 Symphony Schematic

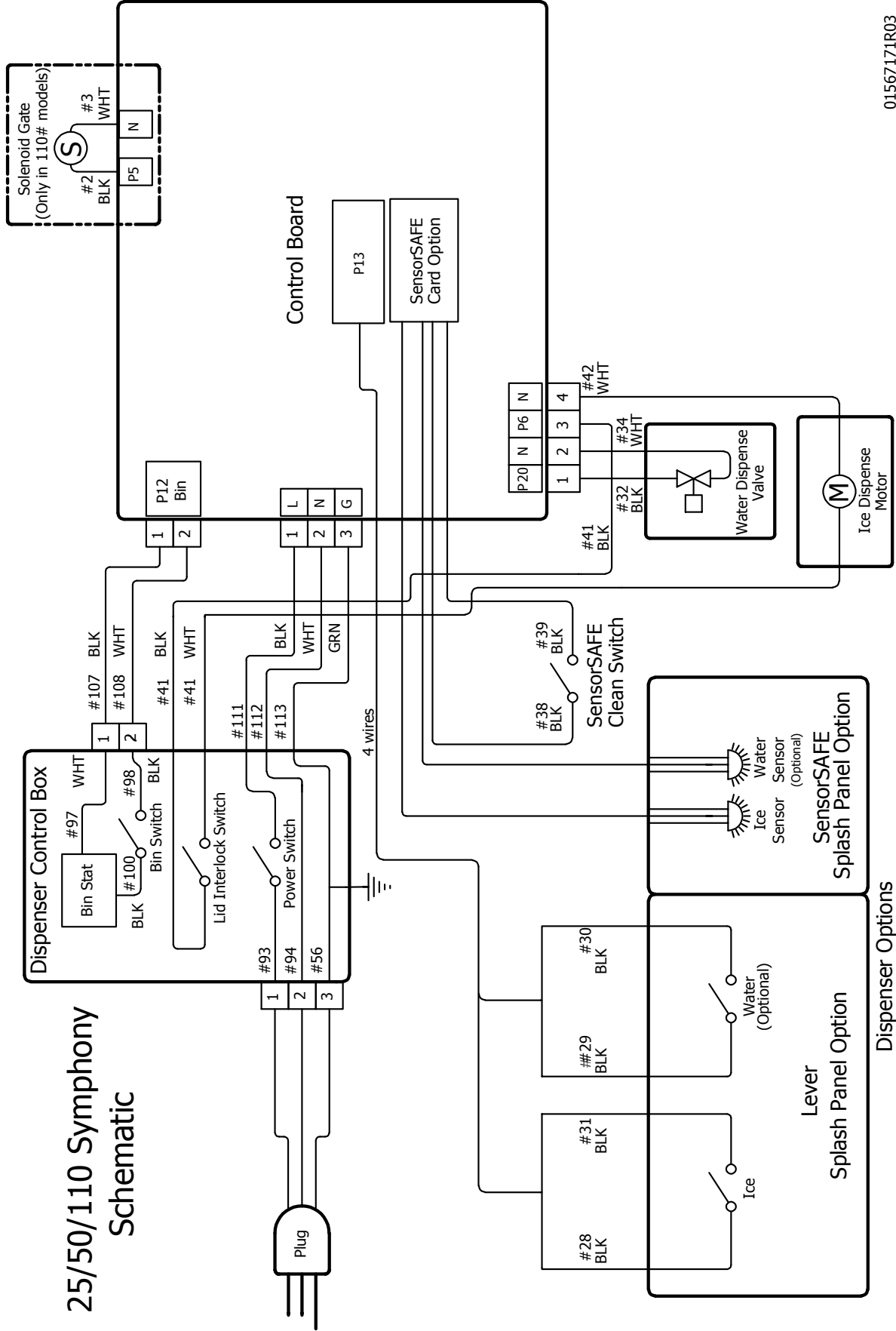

01567171R03

Dispenser troubleshooting

CAUTION!

- Disconnect power to unit before putting hands or arms in storage area or attempting any repair or service to equipment.

Before calling for service

1. Check that no ice is in the dispenser bin area.
2. Check that congealed ice is not causing a jam.
3. Check that all switches and circuit breakers are on.
4. Check that all drains are clear.

Lever model troubleshooting guide

Problem	Indicators	Corrective Action
Does not dispense ice.	<ol style="list-style-type: none"> 1. Power switch off or faulty. 2. Faulty dispense switch. 3. Wheel motor malfunction. 4. Defective control board. 5. Defective wiring. 	<ol style="list-style-type: none"> 1. Turn on or replace the defective switch. 2. Replace defective switch. 3. Verify voltage at motor and replace wheel motor if defective. 4. Jumper pins 1 & 2 on connector P13. <ol style="list-style-type: none"> a. Control board output LED, D19 should light. Replace board, if D19 does not come on. b. D19 comes on but no voltage at wheel motor. Move connector from P6 to L1, if motor runs, replace control board. 5. Ohm check wiring going from lever switch to P13 pins 1 & 2. Ohm check wiring from P6 to wheel motor and neutral wire to neutral on control board. Repair or replace as needed.
Dispense wheel rotates continuously.	Dispense switch contacts are welded together.	Replace dispense switch.
Ice machine runs continuously.	Faulty or incorrectly positioned bin thermostat.	Check for proper positioning. If thermostat does not open when ice is placed on capillary tube, replace thermostat.
Does not dispense water.	<ol style="list-style-type: none"> 1. Power switch off/faulty. 2. Faulty water dispense switch. 3. Water dispense solenoid malfunction. 4. Defective control board. 5. Defective wiring. 	<ol style="list-style-type: none"> 1. Turn on or replace the defective switch. 2. Replace defective switch. 3. Verify voltage at water dispense solenoid and replace water dispense solenoid if defective. 4. Jumper pins 3 & 4 on connector P13. <ol style="list-style-type: none"> a. Control board output LED, D21 should light. Replace board, if D21 does not come on. b. D21 comes on but no voltage at wheel motor. Move connector from P20 to L1, if motor runs, replace control board. 5. Ohm check wiring going from lever switch to P13 pins 3 & 4. Ohm check wiring from P20 to wheel motor and neutral wire to neutral on control board. Repair or replace as needed.

SensorSAFE model troubleshooting guide

Problem	Indicators	Corrective Action
Does not dispense ice.	<ol style="list-style-type: none"> 1. Power switch off or faulty. 2. Power on but no ice dispensing 3. Faulty ice dispense sensor. 4. Wheel motor malfunction. 5. Defective control board/daughter card. 6. Defective wiring. 	<ol style="list-style-type: none"> 1. Turn on or replace the defective switch. 2. Verify daughter card is properly aligned and inserted with pins on the control card and bin lid jumper is installed. 3. Follow the steps below for ice dispensing. <ol style="list-style-type: none"> a. If ice and water dispenser, switch connectors going from sensors to daughter and if problem follows to opposite input, replace defective sensor. b. Once switched, if problem stays with same input, jumper pins 3 & 4 on daughter card ice connector and the control board output LED, D19 should light. Replace board, if D19 does not come . 4. Verify 120 vac at motor and replace wheel motor if defective. 5. D19 comes on but no voltage at wheel motor. Move connector from P6 to L1, if motor runs, replace control board. 6. Ohm check wiring from P6 to wheel motor and neutral wire to neutral on control board. Repair or replace as needed.
Does not dispense water	<ol style="list-style-type: none"> 1. Power switch off/faulty. 2. Faulty water dispense sensor. 3. Water dispense solenoid malfunction or defective control board/daughter card. 4. Defective wiring. 	<ol style="list-style-type: none"> 1. Turn on or replace the defective switch. 2. Follow the steps below for water dispensing. <ol style="list-style-type: none"> a. If ice and water dispenser, switch connectors going from sensors to daughter and if problem follows to opposite input, replace defective sensor. b. Once switched, if problem stays with same input, jumper pins 3 & 4 on daughter card water connector and the control board output LED, D21 should light. Replace control board/daughter card, if D21 does not come on. If D21 comes on, move connector from P20 to L1, if solenoid energizes, replace control board. 3. Verify 120 VAC at solenoid and replace if present. 4. Ohm check wiring going from water solenoid to P20 terminal on control board. Ohm check wiring from water solenoid neutral wire to neutral on control board. Repair or replace as needed.
Ice machine runs continuously.	Faulty or incorrectly positioned bin thermostat.	Check for proper positioning. If thermostat does not open when ice is placed on capillary tube, replace bin thermostat.

Disassembly and replacement instructions

Dispense chute removal

1. Remove dispenser front cover.
2. Slide plastic dispense chute up and out to remove.

Dispense wheel and drive bar removal

1. Remove all ice from storage area of dispenser.
2. Remove center thumbnut from dispense wheel.
3. Remove thumbnuts holding baffle inside bin and remove baffle.
4. Tilt rear of wheel up and lift off motor drive shaft.
5. After reinstalling wheel, secure baffle loosely with thumbnuts, but do not tighten.
6. Place a 1/8" (3.2 mm) spacer against wheel and allow baffle to drop until it touches spacer.
7. Tighten thumbnuts and remove spacer.

Drive bar removal

1. Remove dispense wheel from dispenser (see above).
2. Pull drive bar out of its channel in bottom of wheel.

Wheelmotor removal

1. Shut water off. Remove front cover.
2. Remove dispense wheel and dispense chute covers (see above).
3. Remove splash panel. Water line to solenoid valve can be disconnected from water inlet valve by pulling on ring at end of inlet fitting.
4. Disconnect wiring to panel and set panel aside.
5. Disconnect wires on motor.
6. Remove four bolts (7/16" socket) holding motor assembly to bottom of dispenser.
7. Remove motor assembly.

Fig. 2

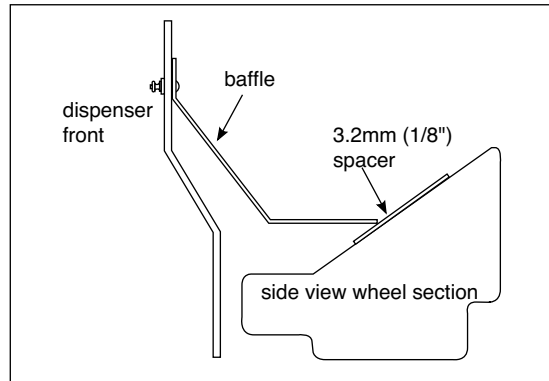

Ice transport tube replacement – Freestanding units

Models 110FB414A/W

1. Remove top and rear access panel from dispenser (lower front panel in freestanding unit).
2. Disconnect existing ice tube from engaging pin on transport tube bracket in ice storage bin and pull down through dispenser chase.
3. Disconnect opposite end of tube from ice machine.
4. Run end of new ice transport tube with 3/16" (5 mm) hole through internal chase in rear inside corner of dispenser (left side as you face dispenser) and push up into storage area.
5. Push the 3/16" (5 mm) hole near end of tube into pin on ice tube bracket (**Fig 6**).

Fig. 3

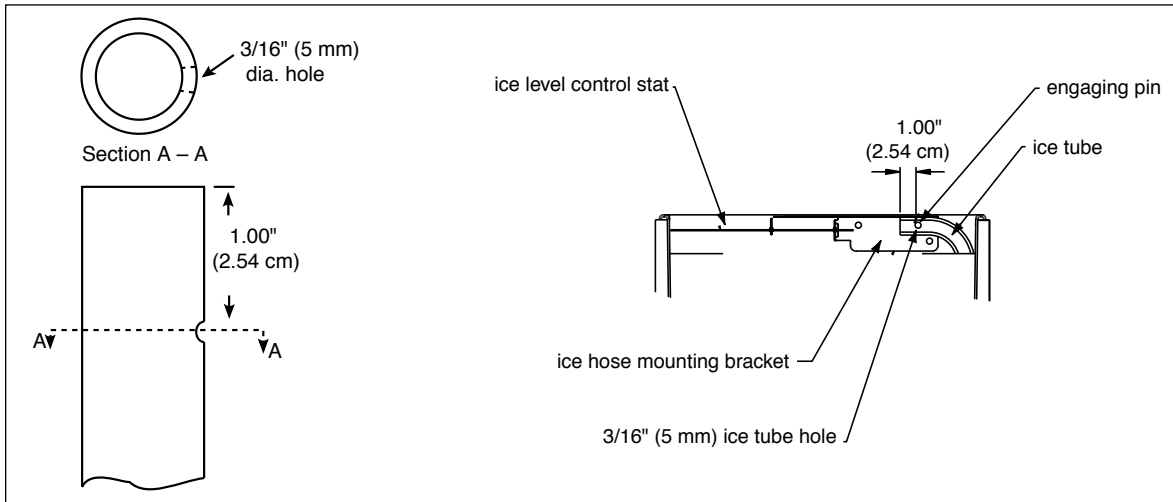

6. Slip supplied hose clamp on opposite end of new ice transport tube. Place end of tube in cup of hot water to soften and spread with pliers to ease assembly and prevent coupler edge from cutting inner wall of tube (**Fig 7**).

Fig. 4

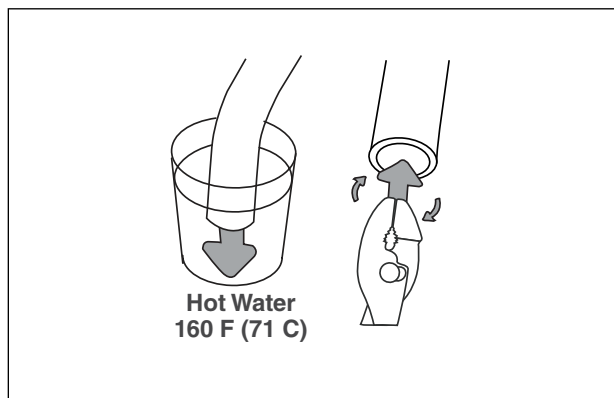

7. Carefully push tube onto icemaker. *Do not twist hose when securing to evaporator.*

Note: Only use tubing supplied by Follett Corporation.

8. Fasten tube on port with hose clamp, ensure that clamp is positioned on evaporator side of nozzle flange.
9. Tighten clamp.

Thermostat replacement

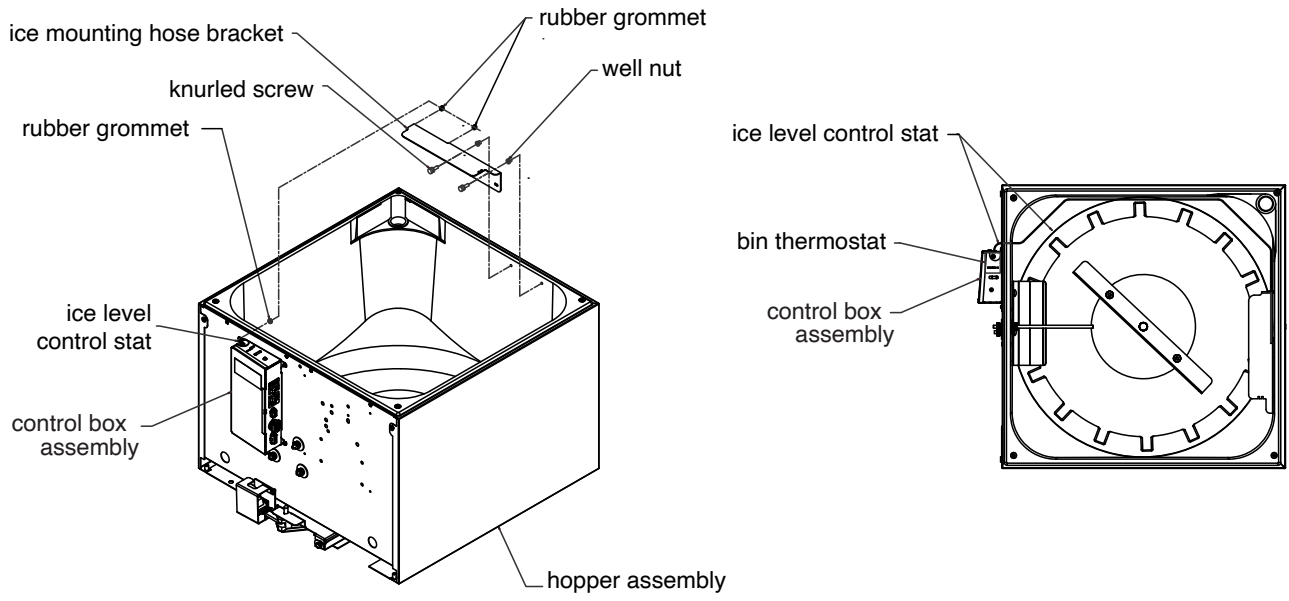

Replacement parts

Dispenser exterior

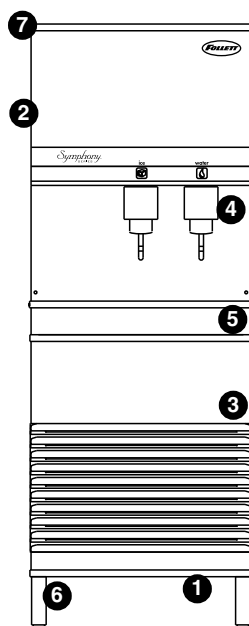

Reference	Description	Part #
1	Screw, knurled, 1/4-20 x 1"	01059855
2	Cover, top front, FB, ice and water	01072792
3	Cover, lower section, FB	502704
4	Cover, dispense chute	502681
Not shown	Knurled screws, front cover	01085703
5	Drain pan	502705
Not shown	Grille, drain pan	502706
6	Single leg, for freestanding units	502298
7	Lid, secured, 110 freestanding (FB)	01572155
Not shown	Leg kit, for freestanding units – set of 4	502088
Not shown	Drain tube assembly	502711
Not shown	Cover, top front, CT, ice only	01072826
Not shown	Cover, top front, FB, ice only	01072800
Not shown	Tee, water inlet, 1/4"	502923
Not shown	Valve, water shut-off, 1/4"	01035526
Not shown	Drain fitting, plastic, ice machine (includes screws)	00109728
Not shown	Cord, power, dispenser	01027648
Not shown	Cord & plug, bin signal, RIDE ice machine, 20'	01074202
Not shown	Cord & plug, bin signal, top mount and freestanding	01074210
Not shown	Clean switch, SensorSAFE	502359
Not shown	Cord & plug, ice machine power, FB and CT (dispenser box to ice machine box)	01074848
Not shown	Caster	502805

Wheelmotor and drive svstem

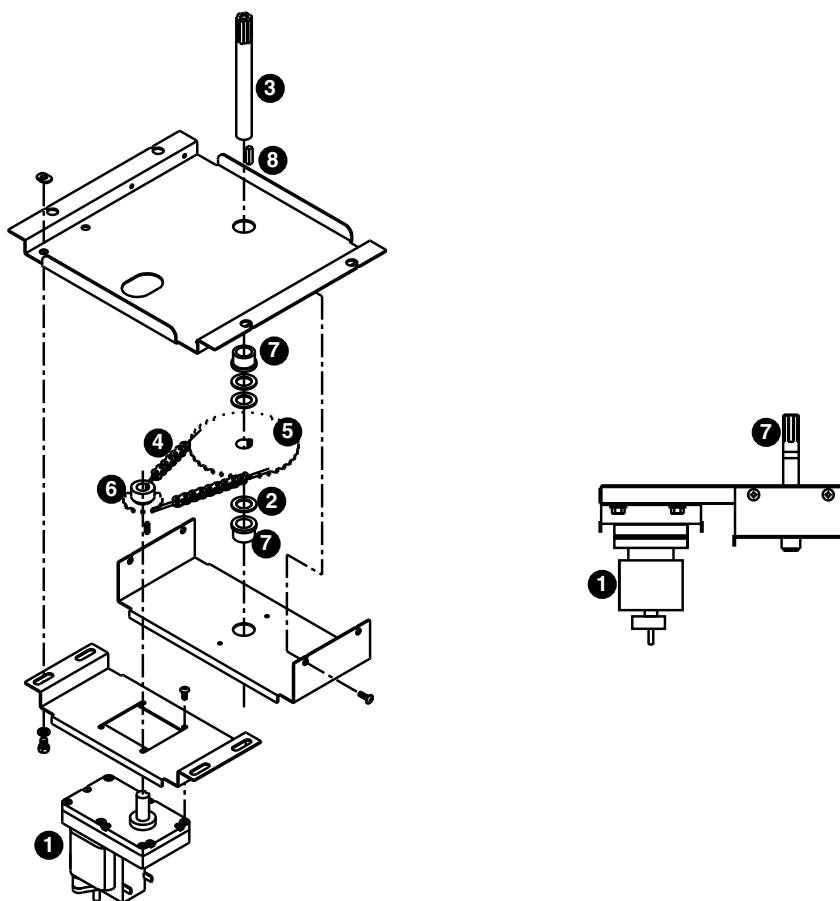

Reference	Description	Part #
1	Wheelmotor, 120 V, 60 Hz	501861
2	Washer, thrust	501026
Not shown	Fan blade, wheelmotor	501607
3	Drive shaft (includes key and stud)	501619
4	Chain, pitch 54, link	502691
5	Sprocket, drive shaft, 35T	502692
6	Sprocket, wheelmotor, 10T	501019
7	Bearing, drive shaft	501024
Not shown	Connecting link, chain	500799
8	Key, drive shaft	500637
Parts 1-8 above	Dispenser drive assembly	502020

Dispense chute and splash panel (models with lever dispensing)

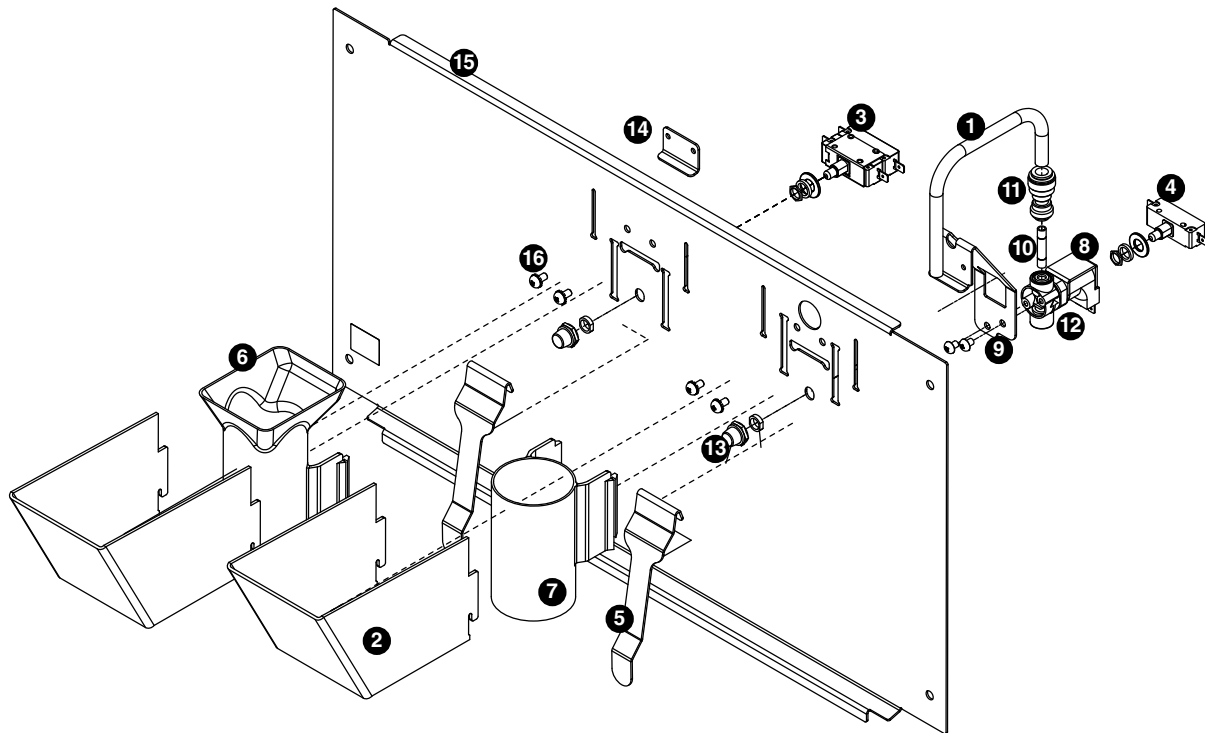

Reference	Description	Part #
1	Tube, water station	502356
2	Cover, dispense chute	502681
3	Switch, dispense, ice, lever actuated (includes 501841)	501829
4	Switch, dispense, water, lever actuated (includes 501841)	502359
5	Lever, dispense	00976845
6	Chute, ice (with Agion® antimicrobial product protection ¹)	01042787
7	Chute, water (with Agion)	01042795
8	Solenoid assembly, water, 120 V 60 Hz (includes solenoid valve, mounting bracket, outlet fittings, dispense tube)	01352608
9	Bracket, lever and water solenoid	01352574
10	Tube, connector, 1/4" stainless steel	01352517
11	Fitting, 1/4" tube to 3/8" tube	01230671
12	Solenoid valve, water, 120 V, 60Hz	01352483
13	Boot, dispense switch button	501841
14	Bracket, lever	00958793
15	Splash panel, lever dispense	01039742
16	Fastener, 10-32 x 3/8" stainless steel	00982421
Not shown	Tubing, water station, thermoplastic, 1/4" OD (sold by the foot)	502079
Not shown	Splash panel, lever dispense complete assembly	01352707
Not shown	Splash panel, lever dispense, ice only, complete assembly	01352723

¹ Disclaimer: Antimicrobial protection is limited to the treated components and does not treat water or ice.

Dispense chute and splash panel (models with SensorSAFE infrared dispensing)

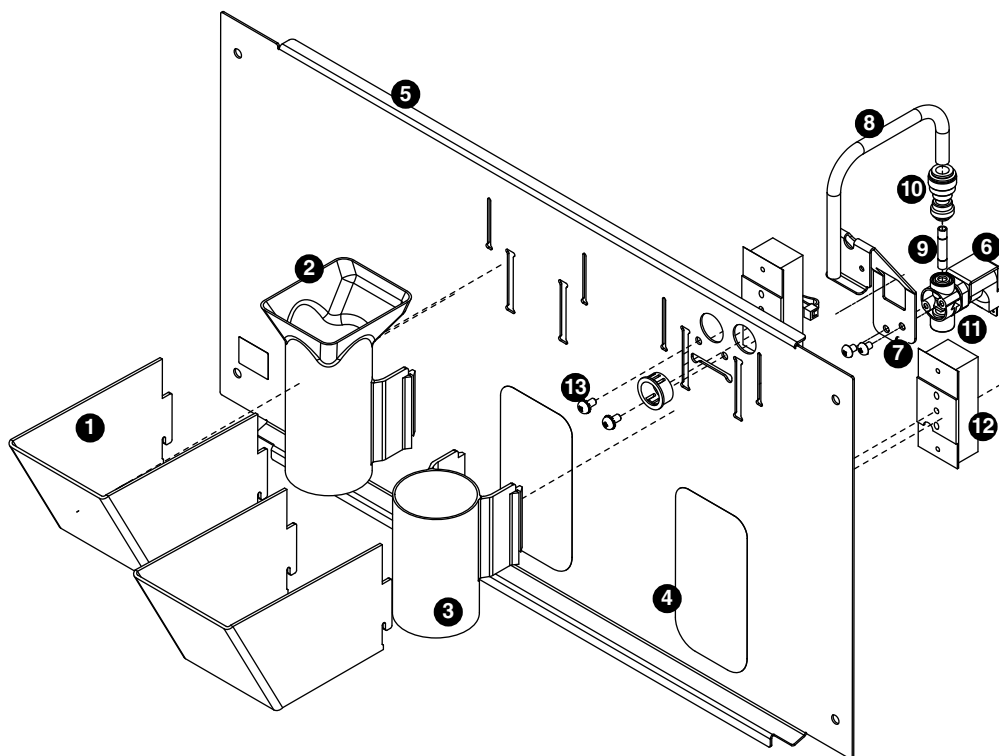

Reference	Description	Part #
1	Cover, dispense chute	502681
2	Chute, ice (with Agion® antimicrobial product protection ¹)	01042787
3	Chute, water (with Agion)	01042795
4	Lens, sensor	502690
5	Splash panel (includes 2 of 502690)	01049162
Not shown	Splash panel, SensorSAFE, ice only (includes 2 of 502690)	01049170
6	Solenoid assembly, water, 120 V 60 Hz (includes solenoid valve, mounting bracket, outlet fittings, dispense tube)	01352608
7	Bracket, lever and water solenoid	01352574
8	Tube, water station	502356
9	Tube, connector, 1/4" stainless steel	01352517
10	Fitting, 1/4" tube to 3/8" tube	01230671
11	Solenoid valve, water, 120V, 60Hz	01352483
12	Sensor (includes lens and ty-rap)	00122978
13	Fastener, 10-32 x 3/8" stainless steel	00982421
Not shown	Splash panel, SensorSAFE, complete assembly	01352699
Not shown	Splash panel, SensorSAFE, ice only, complete assembly	01352715

¹ Disclaimer: Antimicrobial protection is limited to the treated components and does not treat water or ice.

Electrical components

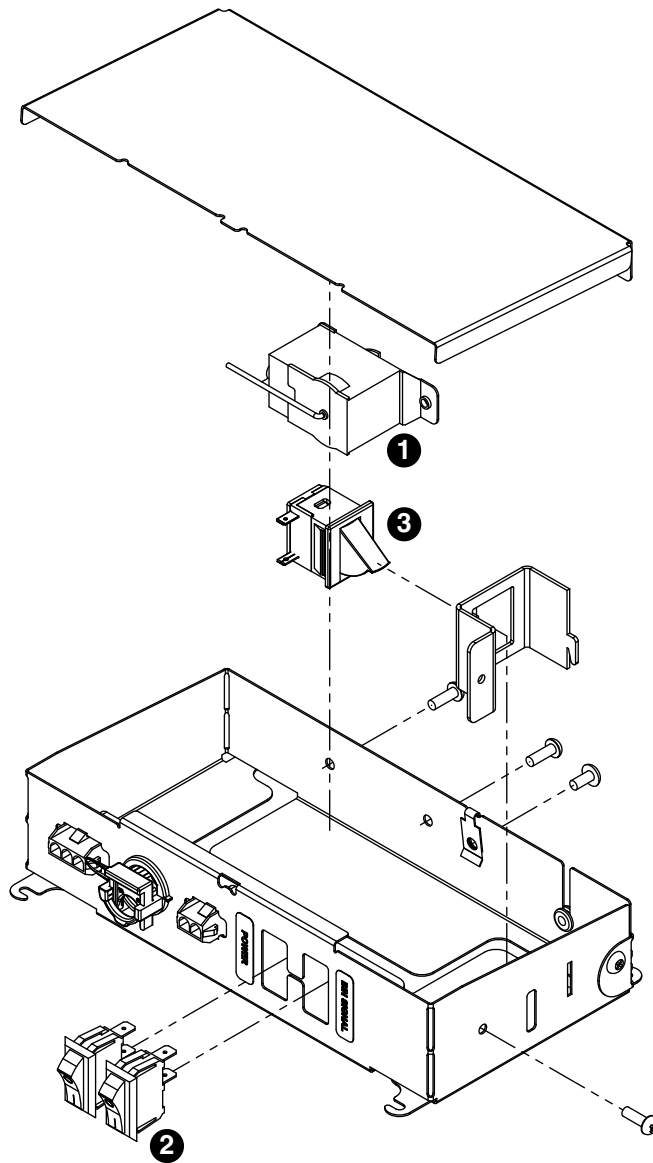

Reference #	Description	Part #
1	Thermostat	500514
2	Switch, dispenser power	502209
2	Switch, ice machine bin signal	502209
3	Bin interlock switch	01541044
Not shown	Cord and plug, ice machine power (dispenser box to ice machine box)	01215128
Not shown	Cord and plug, bin signal (dispenser box to ice machine box)	01215144
Not shown	Power cord	01027655
Not shown	Ice maker control board	01572189
Not shown	SensorSafe board (daughter card)	01544238

Hopper components

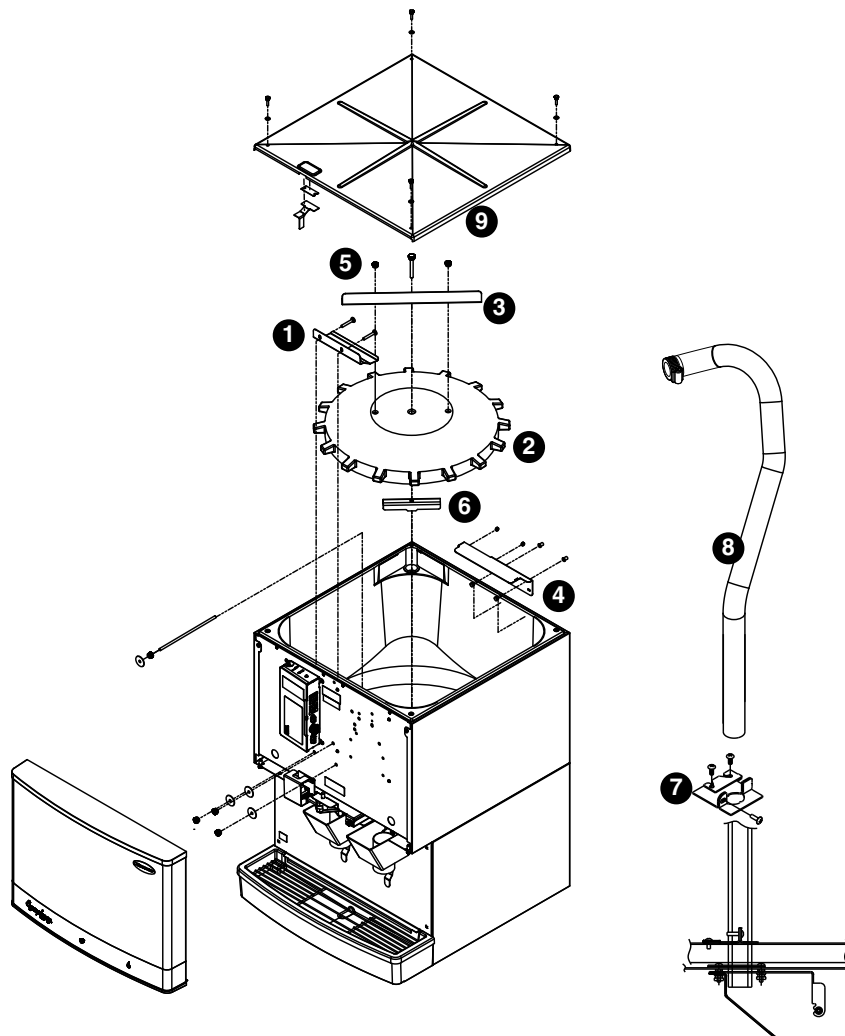

Reference	Description	Part #
1	Baffle, ice	501802
2	Wheel, dispense (includes drive bar, rotating agitator, threaded bar & rod)	501493
3	Agitator, rotating	501494
4	Bracket, ice tube	502712
5	Screw	501100
Not shown	Rod, threaded (includes knurled nut)	501612
6	Drive bar assembly (includes threaded rod and nut)	501617
7	Bracket, ice tube entry (units with top mounted ice machine)	01067644
8	Ice transport tube assembly (units with top mounted ice machines)	01003532
9	Lid, secured, FB	01572163
Not shown	Drain pan, hopper	00115196

Ice transport tubing

Reference	Description	Part #
Not shown	Ice transport tube (RIDE units) - 10 ft	502522
Not shown	Ice transport tube (RIDE units) - 20 ft	502523
Not shown	Ice transport tube insulation (RIDE units only) - sold by the foot	501176
Not shown	Ice transport tube assembly (50 FB units)	502328
Not shown	Ice transport tube assembly (25 FB units)	502329
Not shown	Ice transport tube assembly (top mount units)	01003532

Chilled water components

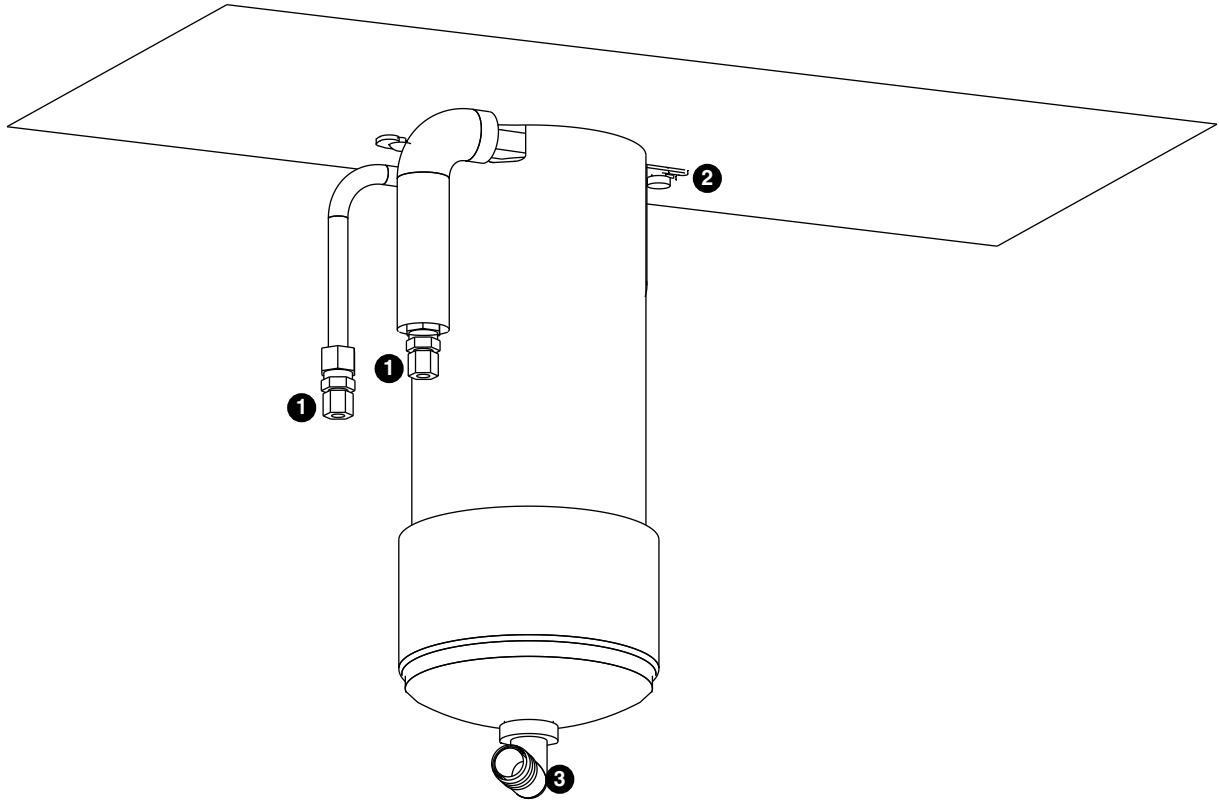

Reference	Description	Part #
Not shown	Coil, chilled water (includes two 502599)	01074111
1	Fitting, water coil	502599
2	Brackets, chilled water canister, pair (includes screws)	502600
3	Elbow, drain	502605
Not shown	Assembly, chilled water	01074137
Not shown	Tubing	01055011

Dispenser plumbing connections

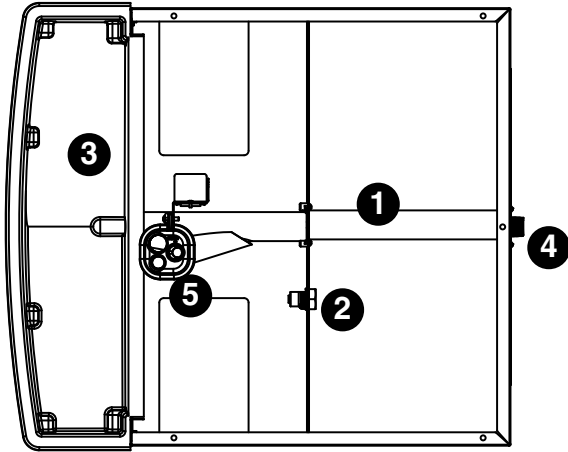

TOP VIEW

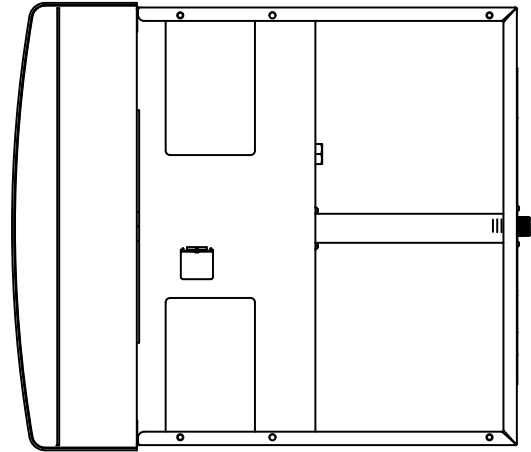

BOTTOM VIEW

Reference	Description	Part #
Not shown	Valve, water shut-off	01035526
1	Tube, drain pan and cup, includes drain cup	01074285
2	Fitting, water inlet	01065275
3	Drain pan	502705
4	Fitting, drain	00109728
5	Drain cup	01540327
Not shown	Tee, water inlet, 1/4"	502923
Not shown	Grille, drain pan	502706
Not shown	Diverter, overflow, drain cup, 110FB	01449636

Solenoid dispense assembly

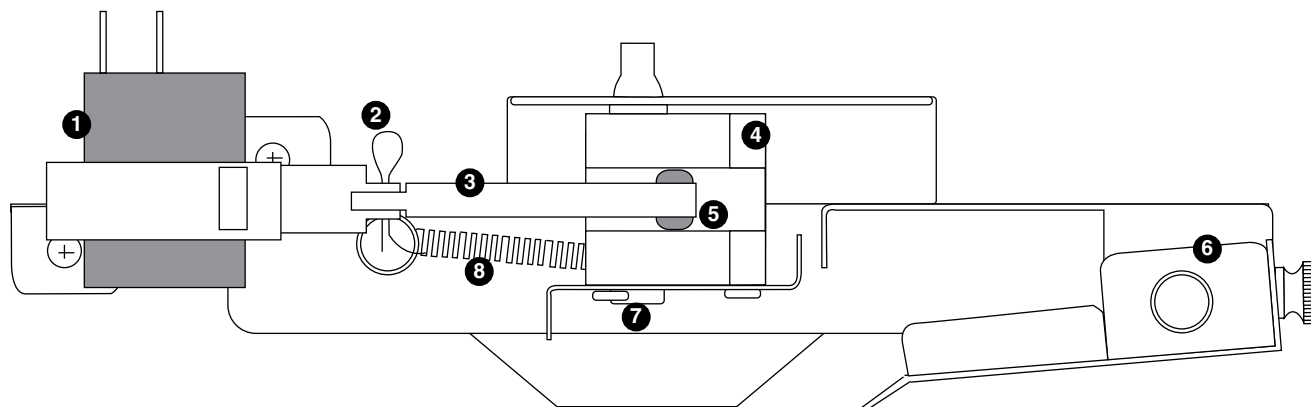

Reference #	Description	Part #
1	Solenoid, dispense	501830
2	Cotter pin	502040
3	Linkage, solenoid (includes 502054 grommet)	502039
4	Block, dispense gate	502042
5	Grommet	502054
6	Splash pan, gate assembly	502045
7	Shoulder screw and washer	502038
8	Spring, gate assembly	501824
—	Gate assembly, 115V (includes reference numbers 1 through 8 above)	502043

Water treatment accessories for Symphony Plus ice and water dispensers

Description	Old part number (and capacity)	New Part Number (and capacity)
Carbonless high-capacity water filter system	01050442 (15,000 gal)	CARBONLESSHICAPSYS (Based on water conditions)
Carbonless high-capacity water filter cartridge, single	01050426 (15,000 gal)	CARBONLESSHICAPFILTER (Based on water conditions)
Carbonless high-capacity water filter cartridge, carton of 6	01050434 (15,000 gal)	CARBONLESSHICAPFILTER6 (Based on water conditions)
Standard capacity carbon filter system	00130229 (3,000 gal)	CARBONSTDCAPSYSTEM (5,000 gal)
Standard capacity carbon filter cartridge, single	00130245 (3,000 gal)	CARBONSTDCAPFILTER (5,000 gal)
Standard capacity carbon filter cartridge, carton of 6	00954297 (3,000 gal)	CARBONSTDCAPFILTER6 (5,000 gal)
High-capacity carbon filter system	00978957 (15,000 gal)	CARBONHICAPSYSTEM (17,500 gal)
High-capacity carbon filter cartridge, single	00978965 (15,000 gal)	CARBONHICAPFILTER (17,500 gal)
High-capacity carbon filter cartridge, carton of 6	00978973 (15,000 gal)	CARBONHICAPFILTER6 (17,500 gal)
Water pre-filter cartridge, single	00130211 (N/A)	SEDIMENTPREFILTER (N/A)
Water pre-filter cartridge, carton of 12	00954305 (N/A)	SEDIMENTPREFILTER12 (N/A)

Reference #	Description	Part #
Other filtration		
Not shown	Claris hardness removal filtration system	00986059
Not shown	Replacement filter for Claris system	00985127
Not shown	Reverse osmosis system, 200 gallons per day	00986034
Not shown	Replacement reverse osmosis cartridge	00985085
Not shown	Replacement reverse osmosis pre-filter	00985077
Not shown	Cleaning plug for reverse osmosis system	00985119
Not shown	Cleaning cartridge for reverse osmosis system	00985101
Water pressure		
Not shown	Water pressure regulator (25 psi)	501781
Cleaning		
Not shown	SafeClean Plus, case of 6	01149954
Not shown	SafeClean Plus, case of 24	01149962
Not shown	Sponge, sanitary, each	00131524
IMS-II or IMS-III sanitizing concentrate		
Not shown	16 oz. bottle	00979674
	Case of 12 x 16 oz. bottles	01038652
	Sponge, sanitary, pack of 24	01075431

Calgon is a licensed trademark distributed by Nu-Calgon, in the United States.
Agion is a registered trademark of Agion Technologies, Inc, Wakefield, MA, USA.
SafeCLEAN, SaniSponge, SensorSAFE, and Symphony Plus are trademarks of Follett Products LLC.
Follett is a registered trademarks of Follett Products LLC, registered in US.



801 Church Lane • Easton, PA 18040, USA
Toll free (877) 612-5086 • +1 (610) 252-7301
www.follettice.com

01573823R02
© Follett Products LLC 12/25